

# And Baby Makes 3...4...5...

R+E Cycles is one of the few manufacturers that can build bicycles for 3, 4, 5...you name it! We haven't ever put them in the catalog, and I don't know why.

Over the last several years we've built dozens of long bikes (bikes longer than tandem). Some of which, like the one I'm riding below, will convert to a tandem with the use of S&S Couplings. The quint in the line art drawing below is shown on the next page on the frame table in progress. Dennis built this frame about 2 years ago. The final bike wound up from wheel to wheel almost 15 feet long! Every long bike creation is built custom, and is quoted out individually. Our price is generally quite a bit less than the other manufacturers. We also don't mind building these monsters at any time. Some manufacturers will only build them in the off season.

If your family has grown to the point where you think you might like to try a triple, quad, or quint, don't buy before getting a quote from us. You might be pleasantly surprised.

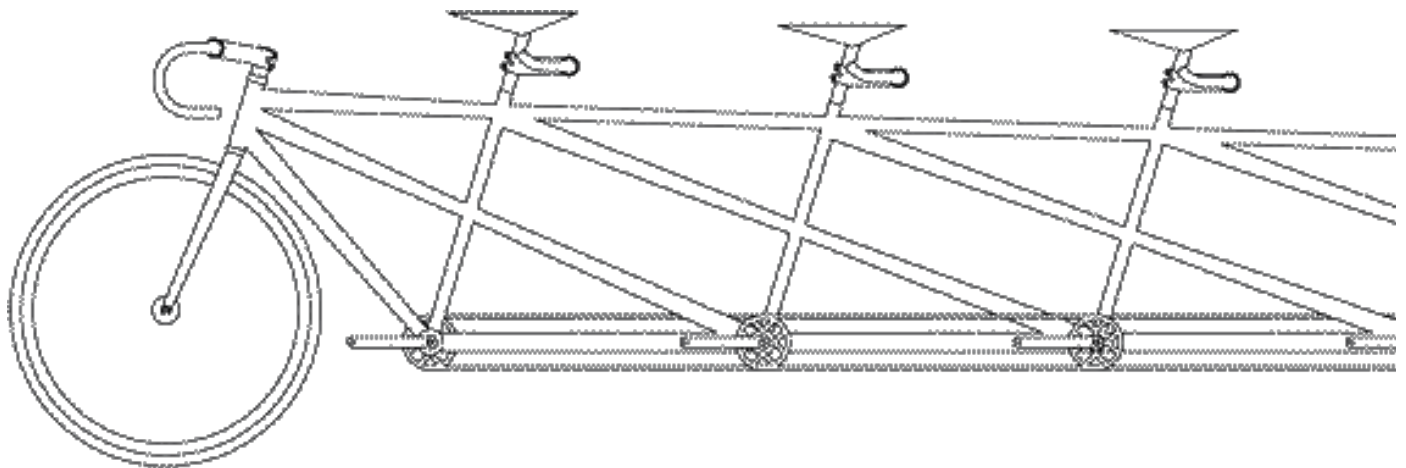

## Team Rodriguez

The Towle's (us) ride our quad in Southern Idaho on the way to the 4th of July parade.

See more in our customer scrapbook at [www.rodcycle.com](http://www.rodcycle.com)



# Team Rodriguez



*Kevin, Dominik and Susan with their Rodriguez travel triple/tandem on tour in France. Read about their travels in our online customer scrapbook at [www.rodcycle.com](http://www.rodcycle.com)*

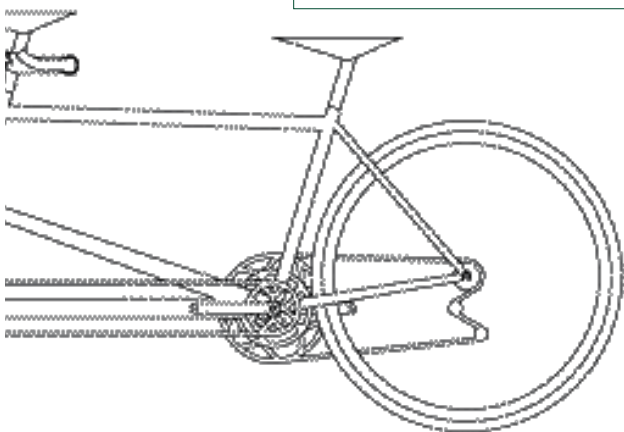

# Team Rodriguez

The Shuharts on their Rodriguez travel triple (Christmas card photo) See more in our customer scrapbook at [www.rodcycle.com](http://www.rodcycle.com)